

# Protector Station Monitor

## Features

- Built-in on/off valve
- Corrosion-resistant aluminum construction
- Direction control handle
- Valve position indicator
- Elevation locking knobs
- Pressure gauge 1/4 in. port
- Drain valve 1/4 in. port

## Description

The Protector is a completely packaged fixed station monitor with many unique features. Its unique (patent pending) water-way has low friction loss and delivers water to the nozzle with fewer twists and turns than a conventional monitor. The built-in on/off valve with position indicator eliminates the need to add a costly valve to the monitor installation.

The Protector can be directly bolted to a common 4 in. pipe flange. The outlet is available with 2.5 inch male NH threads. A long stream-straightening vane in the discharge section reduces turbulence. The simple and basic design requires no grease or other maintenance. Swiveling elements and seals (including valve seat) can be replaced in a few minutes with common hand tools.

Threaded ports (1/4 in. NPT) are provided for drain valve and pressure gauge installation. Maximum pressure is 250 psi. The Protector is constructed of UNS A03560 alloy heat treated to T6 with poly-impregnation casting treatment. It is also hardcoat anodized per military specification MIL-A-8625F Type III, Class 1 and features polyester powder-coated outer surfaces inside and out. The swivel clamps, 3 in. valve ball, trunnions and hardware are 18-8 stainless steel. The monitor may be used to deliver water or foam streams.

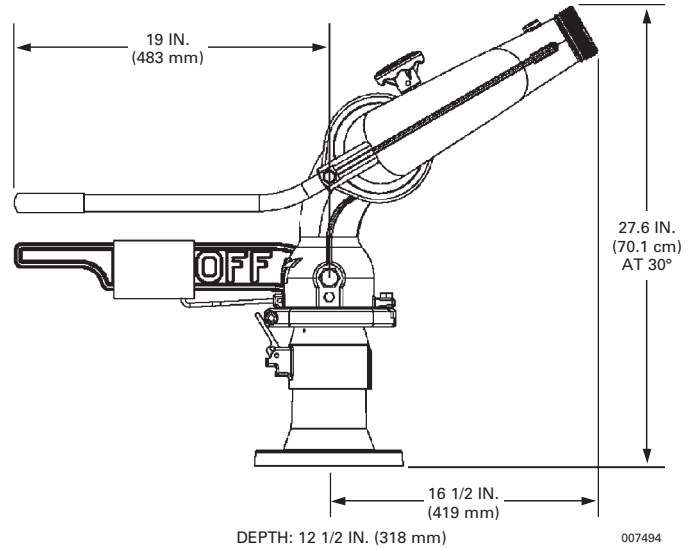

The Protector Station Monitor is recommended for use with ANSUL® Master Stream nozzles and ANSUL Master Foam nozzles.

## Valve Operation

The built-in valve indicates the flow is OFF when the valve handle is horizontal and ON when the handle is vertical. Parts are manufactured so that the valve cannot be assembled out of phase. A position indicator shows the valve positions as "OFF or "ON." The position that the valve is normally left in will depend upon your particular location's standard operating procedure.

## Ordering Information

Part No.	Description	Approximate Shipping Weight	
		lb	(kg)
427469	Protector Station Monitor	51	(23)

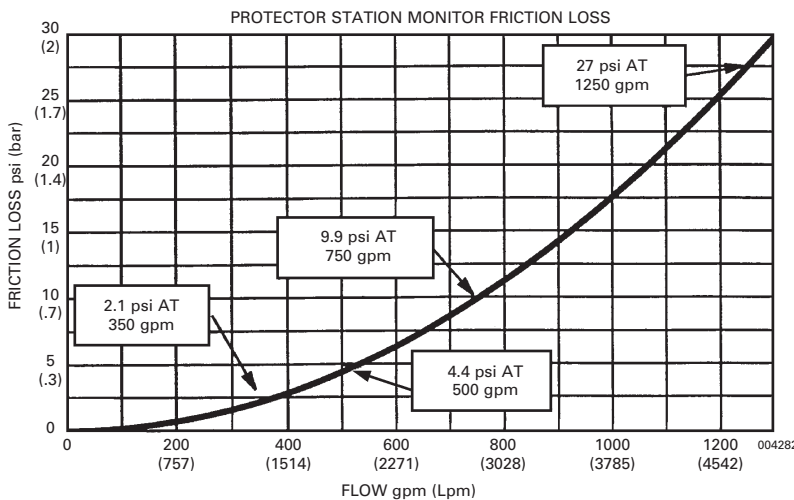

**Note:** The converted metric values in this document are for dimensional reference only and do not reflect an actual measurement.

ANSUL, and the product names listed in this material are marks and/or registered marks. Unauthorized use is strictly prohibited.