

BALANCED PRESSURE PUMP PROPORTIONING SYSTEM

Data/Specifications



FEATURES

- Six Proportioner Sizes to Handle Wide Range of Flows with Minimum Friction Loss
- Diaphragm Valve Design Ensures Accurate Pressure Regulation and Rapid Response to Changes in Flow Demand
- ▶ Choice of Standard Red or Corrosion-Resistant Polyamide Epoxy Finish
- Brass Foam Concentrate Piping Standard for Use in Marine Applications and Other Corrosive Environments
- Compatible with Ansul Foam Concentrates
- Stainless Steel Nameplates for Valve Identification and Instruction

APPLICATION

ANSUL® balanced pressure pump proportioning systems are designed to accurately control the flow of a foam liquid concentrate into a water stream over a wide range of flow rates and pressures. These pump proportioning systems are compatible with ANSUL foam concentrates by matching the required foam concentrate pump output to the proportioner maximum flow demand. For other special requirements, contact Ansul Incorporated, Technical Services, Marinette, WI 54143-2542.

Because they are capable of continuously generating large volumes of foam solution, balanced pressure pump proportioning systems are typically used to protect tank farms, marine docks, chemical processing plants, offshore oil platforms, aircraft hangars, and loading racks.

DESCRIPTION

The balanced pressure proportioning system functions by maintaining an equal pressure in the foam concentrate and water inlets to the proportioner. This balancing ability allows the proportioner to be used over a wide range of flows and pressures. The system will also respond quickly and accurately to changes in the water inlet pressures and flow rates.

The system operates by passing the required portion of foam concentrate from a positive displacement pump to a venturi proportioner with the remaining portion recirculating through a diaphragm valve in the return line to the tank. The diaphragm valve senses and balances the pressures in the foam concentrate and water lines to the proportioner. (The pressures can also be balanced manually by using the manual regulating globe valve and the duplex gauge.) The foam concentrate then enters the proportioner where a built-in orifice regulates the flow of pressurized foam concentrate entering the water stream.

- The skid units are available in six proportioner sizes ranging from 2 to 8 in. with flow rates from 30 to 5500 gpm (114 to 20816 Lpm) as listed under the Proportioner Flow Range Table. Each unit consists of a positive displacement foam pump with electric motor and starter; various control, drain, and check valves; pressure balancing diaphragm valve; duplex gauge; foam proportioner; interconnecting brass pipe; and stainless steel valve identification and system instruction nameplates. The entire assembly is mounted on a steel skid and available with either
- ▶ standard red or corrosion-resistant polyamide epoxy "CR" finish.

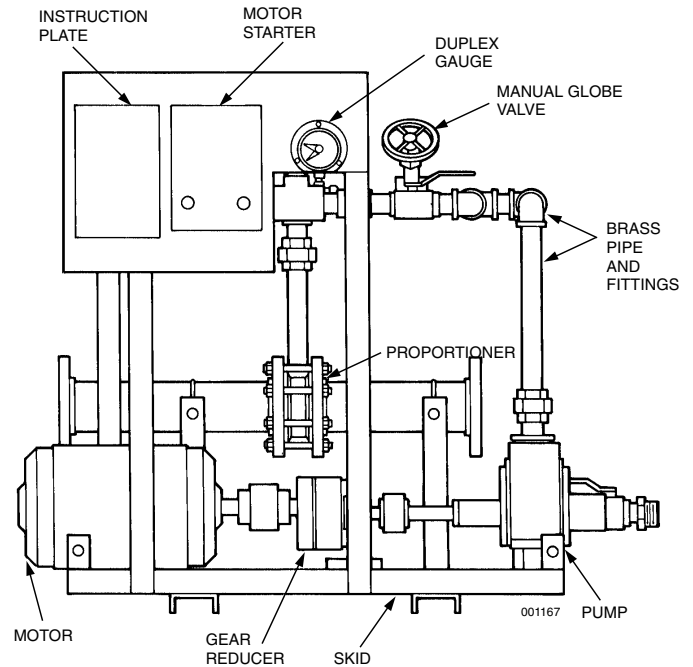

SPECIFICATIONS

The balanced pressure proportioning skid shall contain all necessary components including control valves, proportioner, interconnecting piping, water flush-out connections, positive displacement foam liquid pump, pump driver, and duplex pressure gauge.

Balancing shall be accomplished through the use of a diaphragm pressure balancing valve.

The skid shall have manual override capability through use of a manually-controlled globe valve and duplex pressure gauge. Interconnecting foam concentrate piping shall be of brass construction. Valve nameplates shall be of 304 stainless steel and shall specify valve function and stand-by position.

ORDERING INFORMATION

When ordering, the following information must be provided:

- Type and Percentage of Concentrate
- Minimum and Maximum Water Inlet Pressure Available to Proportioner
- Minimum and Maximum Foam Solution Flow Required
- Power Supply Available
- ▶ ■ Desired Paint System (Standard or Epoxy "CR")

PROPORTIONER FLOW RANGES

Proportioner Size	Approximate Flow Range gpm	(Lpm)
2 in.	30 – 300	(114 – 1136)
2 1/2 in.	35 – 400	(132 – 1514)
3 in.	70 – 800	(265 – 3028)
4 in.	200 – 1600	(757 – 6057)
6 in.	300 – 3400	(1136 – 12870)
8 in.	500 – 5500	(1892 – 20819)

Sensing Lines

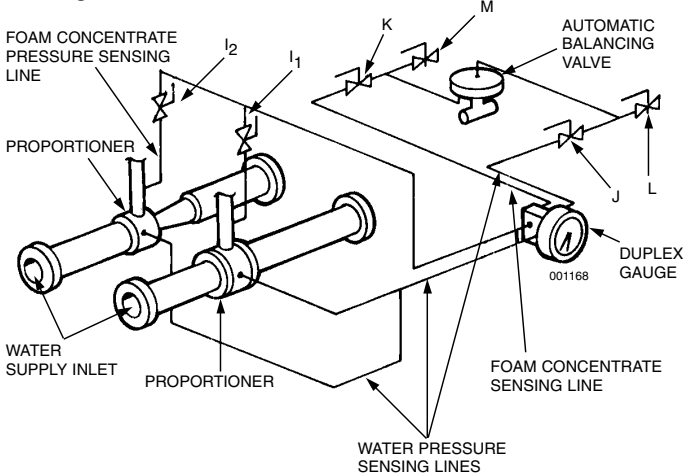

► Depicted for manual operation. Refer to ANSUL Balanced Pressure Pump Proportioning System Manual, Part No. 77166, for installation and operation instructions.

VALVE IDENTIFICATION

Valve	Description
A	Foam Tank Suction
B	Foam Tank Return
C ₁	Foam Proportioner Supply
C ₂	Foam Proportioner Supply (If Required)
D	Manual Foam Balancing
E	Foam Supply to Automatic Balancing Valve
F	Foam Discharge from Automatic Balancing Valve
G	Flush Inlet
H	Flush Outlet
I ₁	Foam Pressure Sensing (If Required)
I ₂	Foam Pressure Sensing (If Required)
J	Water Sensing to Automatic Balancing Valve
K	Foam Sensing to Automatic Balancing Valve
L	Water Flush Out
M	Foam Flush Out

Typical Balanced Pressure Pump Proportioning System

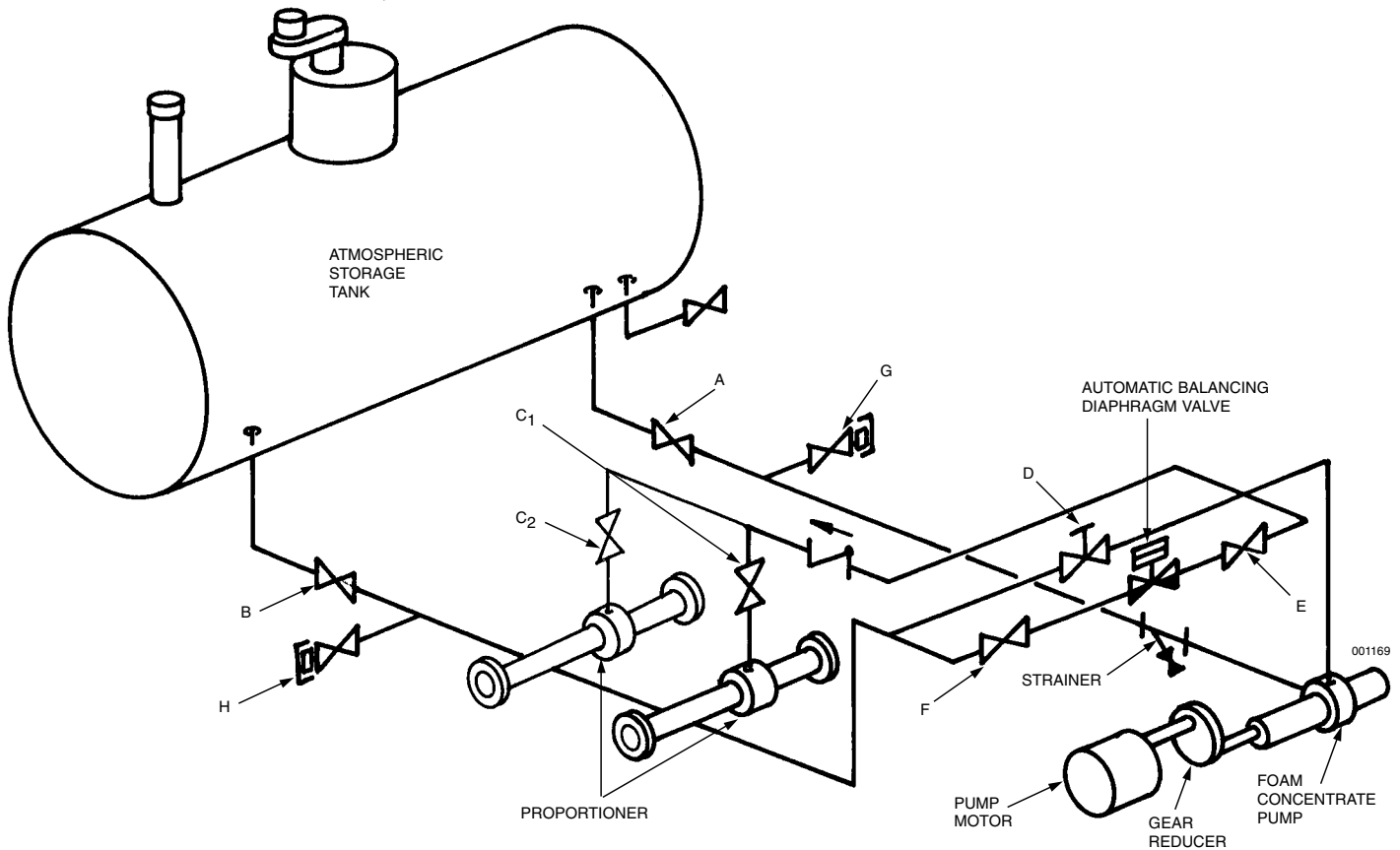

ANSUL is a trademark of Ansul Incorporated or its affiliates.